

### X-Motorspannschlitten 2-Ebenen verstellbar

X-Motorbase 2 planes adjustable

Material: St 37

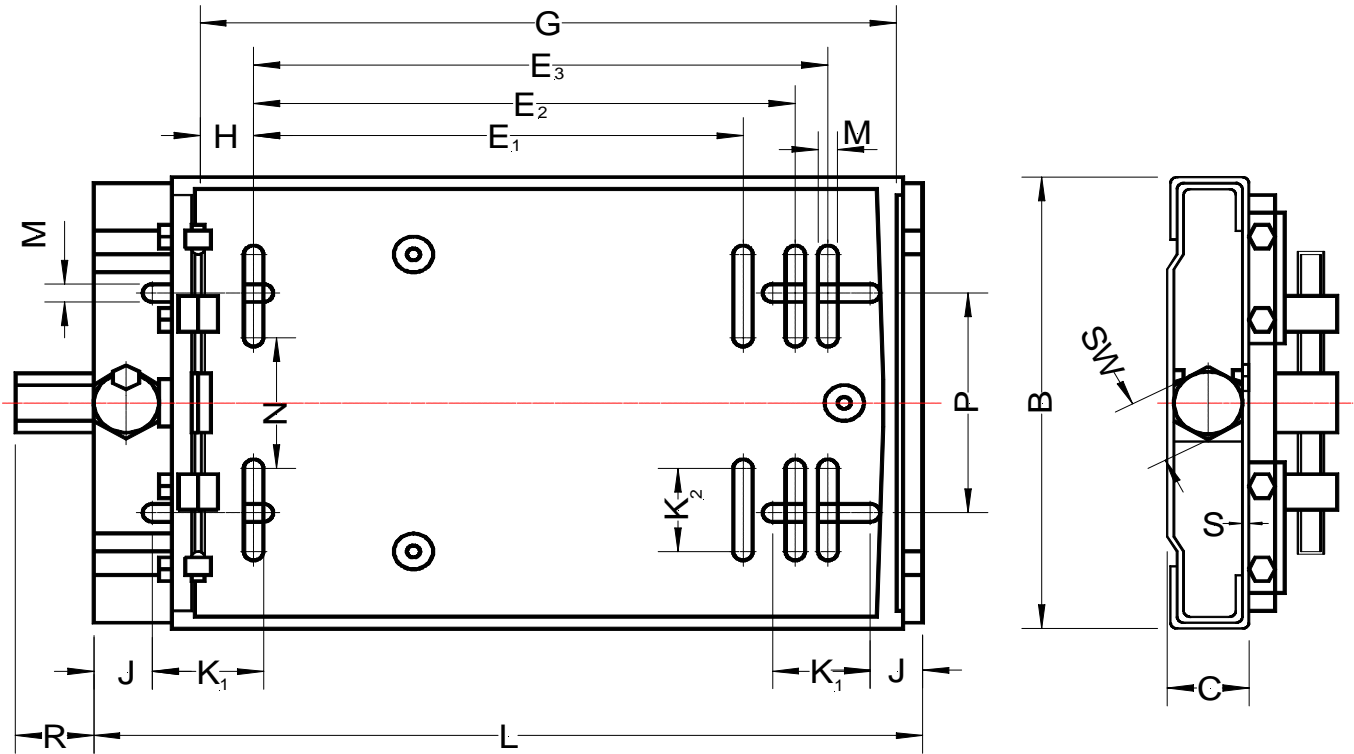

Monoplate-FA-X	L	B	C	E1	E2	E3	G	H	J	K1	K2	M	N	P	R	SW	S
270 - 63 / 90-MP-FA-X	270	194	36	100	125	140	215	40	25	50	50,0	10,5	33	98	20	19	3
307 - 90 / 112-MP-FA-X	307	213	36	140	160	190	270	40	28	50	50,0	10,5	62	108	20	19	3
340 - 100 / 132-2-MP-FA-X	340	290	44	160	190	216	301	50	28	63	47,5	12,5	120	165	25	22	4
430 - 100 / 132-MP-FA-X	430	290	44	160	190	216	301	50	28	63	47,5	12,5	120	165	25	22	4
430 - 160 / 180-2-MP-FA-X	430	370	44		254	279	394	60	30	62	62,0	12,5	163	248	25	22	4
490 - 160 / 180-MP-FA-X	490	370	44		254	279	394	60	30	62	62,0	12,5	163	248	25	22	4
585 - 200 / 225-MP-FA-X	585	450	55		318	356	508	76	30	60	52,0	17,0	248	300	25	22	5

(1) Bei der Type 270 für Baugröße 71 befinden sich im linken Bereich 2 Langlochpaare im Abstand von 28mm um mit E3 das Abstandsmaß 112mm zu erhalten.

The type 270 will be produced with 2 long holes at the left side with a distance of 28mm so that it is possible to mount the motor-size 71.

### min. Verstellwege V

min. regulation range [mm]

Type	Baugrößen											Gewicht weight [kg]	zul. Zugkraft allowed tractive force [N]
	installation size												
	63	71	80	90	100	112	132	160	180	200	225		
270	55											4,0	680
307				37								5,5	940
340					39							10,5	1380
430					129							11,5	1380
430-2							36					16,8	2000
490							96					17,5	2000
585									77			33,0	3800